



Features

- Piezoresistive measuring element
- Gauge, absolute or sealed gauge
- Standard DIN pressure ranges from 0...100 mbar to 0...1000 bar
- Calibration available for all common pressure units
- Complies with the EMC directive 89/336/EEC
- High reliability
- Short delivery time
- Measuring interval programmable from 2 s to 24 h
- Non volatile data memory for 130'000 measurements
- High battery life (up to 10 years)
- Transfer of data to a laptop/handheld computer

Typical applications

- Industrial process control
- Heating and ventilation
- Environmental monitoring
- Food industry
- Test and calibration systems



Specifications

Pressure range	[bar]	0.1 ... 0.5	> 0.5 ... 2	> 2 ... 25	> 25 ... 600	> 600 ... 1000
Overpressure		3 bar	3 x FS (min. 3 bar)	3 x FS	3 x FS (max. 850 bar, optional up to 1500 bar)	1500 bar
Burst pressure	[bar]	> 200	> 200	> 200	> 850 (optional up to 1500 bar)	1500
Accuracy¹⁾	[± % FS]	≤ 0.25	≤ 0.1	≤ 0.1	≤ 0.1	≤ 0.1
Thermal shift	[± % FS/°C]					
Zero	0...70°C	0.06	0.03	0.015	0.015	0.015
	-25...85°C	0.08	0.04	0.02	0.02	0.02
Span	0...70°C	0.015	0.015	0.015	0.015	0.015
	-25...85°C	0.02	0.02	0.02	0.02	0.02
Long term stability (1 year)		< 4 mbar	< 4 mbar	< 0.2% FS	< 0.2% FS	< 0.2% FS

¹⁾ Zero based non-conformity according to DIN 16086, including hysteresis and repeatability

Datalogger

Units	Pressure
Resolution	Pressure < 0.01% FS
Real time clock	Quartz clock with date, start of first measurement programmable
Data memory	130'000 measurement values - non volatile, data kept in memory even without battery - each measurement value is correlated with time and date
Interface	RS232C (V24, three wire)
Identification	Serial number and programmable Id. number
Power supply	Lithium battery 3.6V / size AA - on site battery change
Protection class	IP 65 (cap closed)

Configuration and Data Transfer

PC-Program for Configuration and Data Transfer

System Requirements	IBM compatible laptop or PC, Windows 95/98/NT or handheld PC with Windows CE 2.11 or upward
Data Transfer	- data transfer of last measurement period - data transfer of all data - data transfer for a defined time-period - the data will be represented in a txt.file or in a graph
Configuration	- sampling rate time between two records - number of replicates - time and date - description (e.g. name of location) - starting time of first sample - tare the actual pressure value can be set to the real value (optional) - storage threshold value (optional) - density of the measuring media the density-setting will affect the level range (optional)
Data Format	Data are stored in ASCII format and may be read with programs like Excel, Lotus or similar

Electromagnetic compability

	Standard	Level	Typical interferences
Emission:			
EN 50081-1:1992	Generic emission standard		
EN 55022:1994	Emission, class B		
Immunity:			
EN 50082-2:1995	Generic immunity		
EN 61000-4-2:1995	Electrostatic discharge	4kV contact, 8kV air	
ENV 50140:1993	Radiated electro-magnetic field	10V/m, 80-1000 MHz, 80% AM 1kHz	Cellular phones, radio sets
ENV 50204:1995	Radiated electro-magnetic field (GSM)	10V/m, 950 MHz, 200Hz on/off	Digital portable phones
EN 61000-4-4:1995	Fast transients (burst)	2 kV	Motors, valves
ENV 50141:1993	Conducted radio-frequency	10V, 0.15-80 MHz, 80% AM 1kHz	Cellular phones, radio sets

The pressure transmitter DL fulfill the emission and immunity requirements described in the EMC directive 89/336/EEC.

Ordering Information

		63	X	XXXX	XX61	XX	XXX	
Type	DL	63						
Pressure type	Gauge	1						
	Absolute	2						
	Sealed gauge	3						
Pressure range	0...100 mbar						00	
	0...160 mbar						01	
	0...250 mbar						02	
	0...400 mbar						03	
	0...600 mbar						04	
	0...1.0 bar						05	
	0...1.6 bar						06	
	0...2.5 bar						07	
	0...4.0 bar						08	
	0...6.0 bar						09	
	0...10 bar						10	
	0...16 bar						11	
	0...25 bar						12	
	0...40 bar	3					13	
	0...60 bar	3					14	
	0...100 bar	3					15	
	0...160 bar	3					16	
	0...250 bar	3					17	
	0...400 bar	3					18	
	0...600 bar	3					19	
0...1000 bar	3					20		
	other pressure range						99	
Process connection	G 1/4 female (Fig. 1)						00	
	1/4 NPT M						10	
	1/2 NPT M						19	
	G 1/4 M (Fig. 2)						11	
	G 1/2 M (Fig. 3)						13	
	G 1/2 M, frontal diaphragm (Fig. 4)						14	
	G 1/2 M, flush diaphragm (Fig. 5)						15	
	Special process connection						99	
Electrical connection	Connector RSF 4, 4-pin ²⁾						07	
	Special electrical connection						99	
Interface	RS232C						61	
Accuracy	≤ ± 0.25% FS (for pressure ranges ≤ 500 mbar)						1	
	≤ ± 0.1 % FS (for pressure ranges > 500 mbar)						2	
Temperature range	0...70°C comp. (media temp. 0... 80°C)						0	
	20...100°C comp. (media temp. -25...100°C)						7	
	-25...85°C comp. (media temp. -25...100°C)						1	
	Special temperature range						9	
Options	Throttle ¹⁾						A	
	Special oil filling:	ASEOL Food					G	
		Halocarbon					H	
		AS100 (for media temp. -55 to 150°C)					J	
		PAO4 (silicon free)					Q	
	Seals:	Viton (standard)						U
		EPDM						S
Kalrez							T	
	Theft protection installed						L	

¹⁾ Possible with pressure connection Fig. 2 or Fig. 3 only

²⁾ Data transfer cable not included (ordering code VART009)

Materials

Process connection, diaphragm	Stainless steel 1.4435 (316L)	(other materials on request)
Housing	Aluminium Al MgCl1	(colorless, eloxadized)
Cap	Plastic TEKA Form ELS	
Seals (standard)	Viton	(other materials see ordering information)

Pressure Connection

Dimensions

Electrical Connection

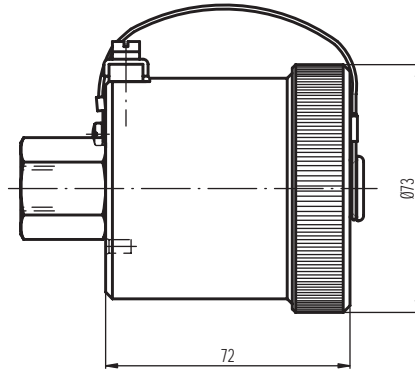
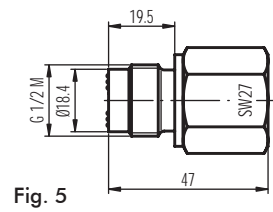
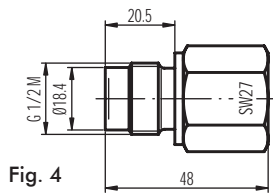
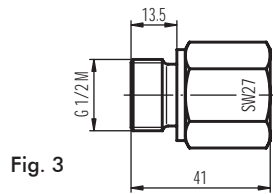
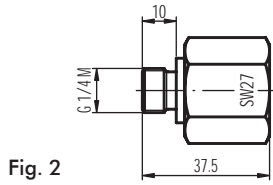
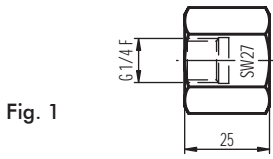

Cable socket connector

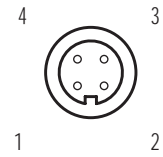

Pin	RS232C
1	TxD
2	RxD
3	GND

Specifications may change without notice. Stand 06/01

